

SNEP®
BY PURSO



SNEP® Mode P

Installation guide
Installationsanleitung

03/05/2024

Keep the instructions and hand them over to the user of the property.

Safety Instructions

Check the products for transport contents and damage. If you notice any defects or shortcomings in the delivery or in a products please contact the seller immediately.

The luminaire must be disconnected from the mains before installation or maintenance work to-avoid the risk of electric shock.

- The luminaire does not come with a terminal block. The installation or maintenance of the luminaire should only be carries out by an authorize person in accordance with these instructions
- The light source of the luminaire may only be replaced by manufacturer, a person authorized by him or an equivalent qualified person.

Bewahren Sie die Installationsanweisung sorgfältig auf und geben Sie diese weiter an den Benutzer der Anlage.

Sicherheitsanweisungen

Das Produkt auf Inhalt und Transportschäden prüfen. Sollten Ihnen Schäden oder Mängel im Produkt oder in Lieferung auffallen, kontaktieren Sie bitte sofort Ihren Händler.

Vor Instandsetzungs-oder Wartungsarbeiten muß die Leuchte vom Netzanschluß getrennt werden um das Risiko eines Stromschlags zu vermeiden

- Die Klemmleiste gehört nicht im Lieferumfang. Die Installations-oder Wartungsarbeiten dürfen nur durch einen autorisierten Fachbetrieb laut diesen Anweisungen durchgeführt werden.
- Die Lichtquelle in der Leuchte darf nur vom Hersteller oder seinem evollmächtigter oder vom gleichermaßen qualifizierten Personal ausgetauscht werden.



Instruction

- No changes may be made to the product
- The manufacturer is not responsible for misuse of the product
- The installed product must not be subjected to external mechanical stress
- The installed product must not be exposed to strong chemicals
- Do not look directly at the luminaire that is on

Service instructions

- If necessary, use neutral soap solutions and non-abrasive cleaners to clean the luminaire

Storage

- The product is stored in a dry and clean environment
- Do not strain the product mechanically or chemically during storage

Brackets:

Use the brackets that came with the shipment only if they are suitable for the intended purpose. If the fasteners are included in the order, they are packaged separately. Please note that for partial shipments, mounts may only be included with the first delivery batch.

The number of fasteners must be used according to the instructions.

Note! When installing sports facilities, one piece/luminaire should be added to the number of brackets used.

Anweisungen

- Veränderungen an das Produkt sind nicht gestattet
- Der Hersteller haftet nicht für Missbrauch des Produkts.
- Das installierte Produkt darf nicht extern mechanisch belastet werden
- Das installierte Produkt darf nicht stark chemisch belastet werden
- Sie dürfen nicht direkt auf die eingeschaltete Leuchte sehen

Wartungsanweisungen

- Falls erforderlich, reinigen Sie die Leuchte mit Neutralseife und nicht scheuernde Reiniger.

Lagerung

- Das Produkt soll in trockenen und sauberen Umgebung gelagert werden.
- Während der Lagerung darf das Produkt nicht mechanisch oder chemisch belastet werden.

Halterungen:

Die mitgelieferten Halterungen nur dann verwenden, wenn die für den Verwendungszweck geeignet sind. Wenn die Halterungen mitgeliefert sind, werden die separat verpackt. Notieren Sie bitte, dass bei Teillieferungen die Halterungen nur in der ersten Teilmenge geliefert werden können. Die Stückzahl von Halterungen muss laut der Anweisung sein (siehe Tabelle)

Achtung! Bei Installation in Sportstätten muss 1 Stück Halterung pro

| Brackets / Luminaires Halterungen / Leuchten | Surface or suspension rail installation Oberflächen- oder Hängeschienen- montage | Ramp installation Rampeninstallation |
|--|--|---|
| Mode P02 | 2 | 2 |
| Mode P04 | 2 | 2 |

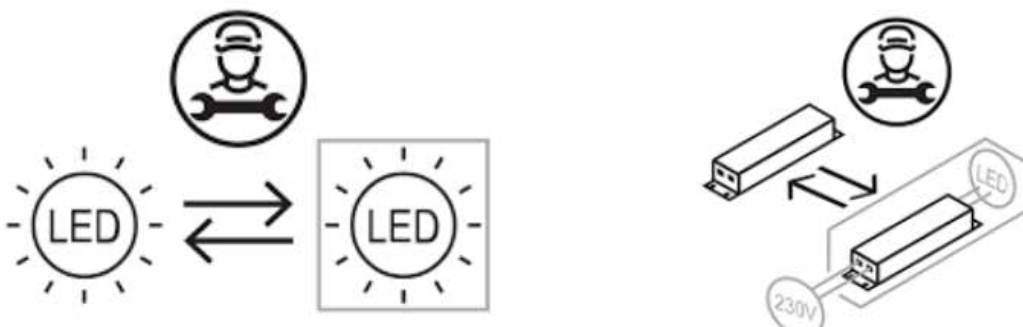

1. Surface mount | Deckenaufbau

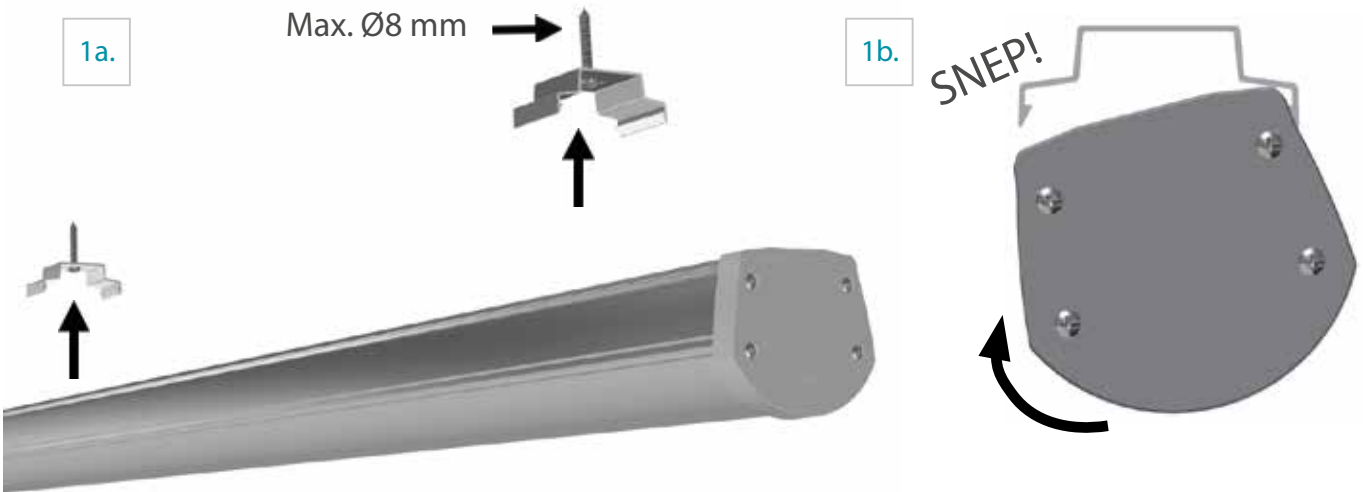

2. Suspension rail installation | Installation auf Montageschie-

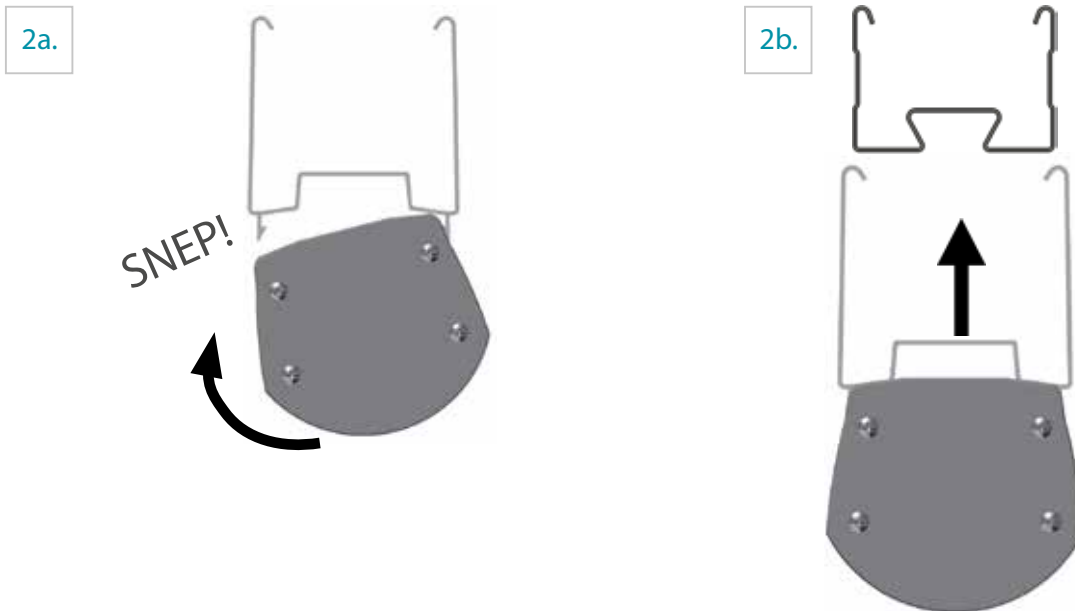

Adjustable bracket | Verstellbare Halterung

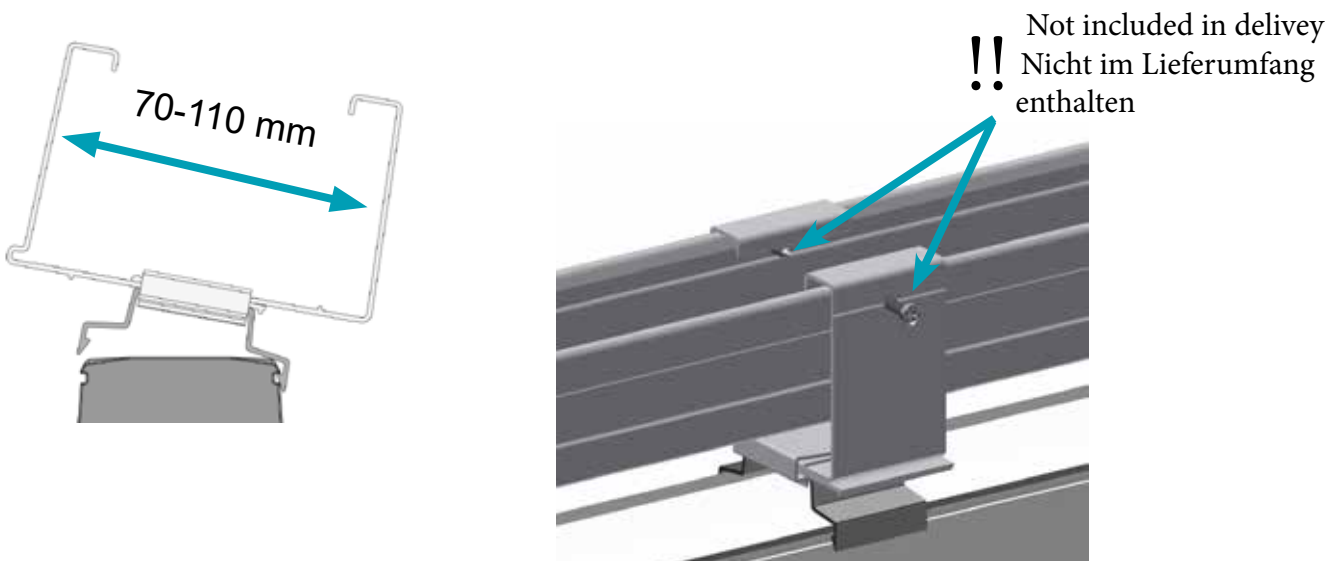

3. Ramp installation | Installation mit Endträgerprofil

3a.

Remove the protective film.
Entfernen Sie die Schutzfolie.



3b.

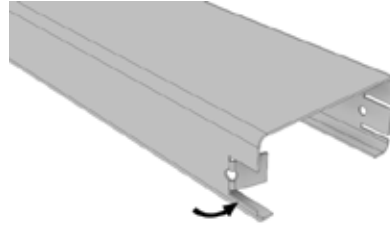

3c.

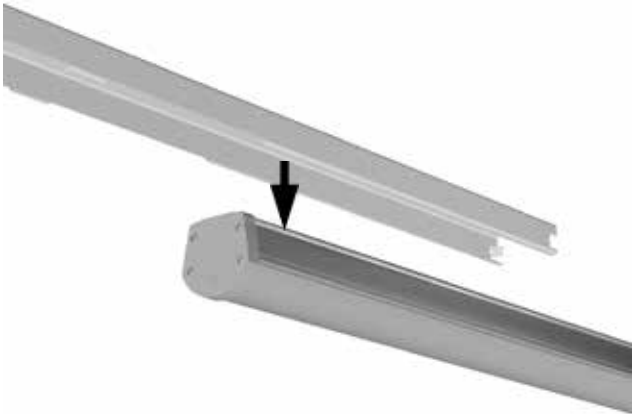

3d.

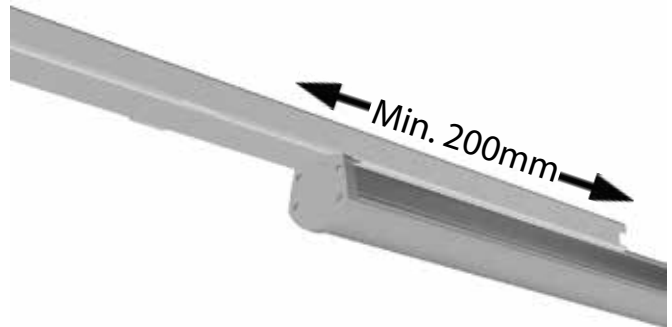

3e.

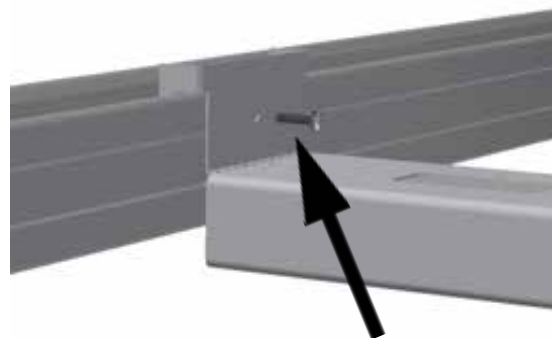
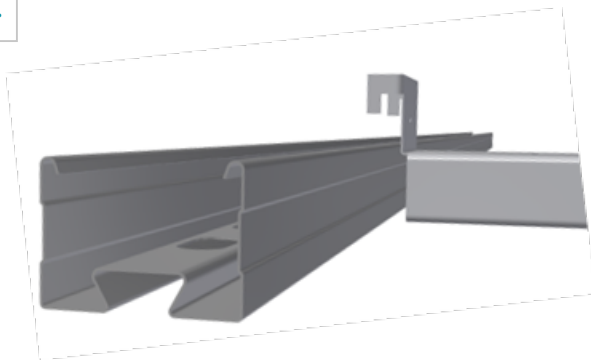

Screw max \varnothing 4.2 mm
Schrauben max \varnothing 4.2 mm

4. Coupling | Anschluss

4a.

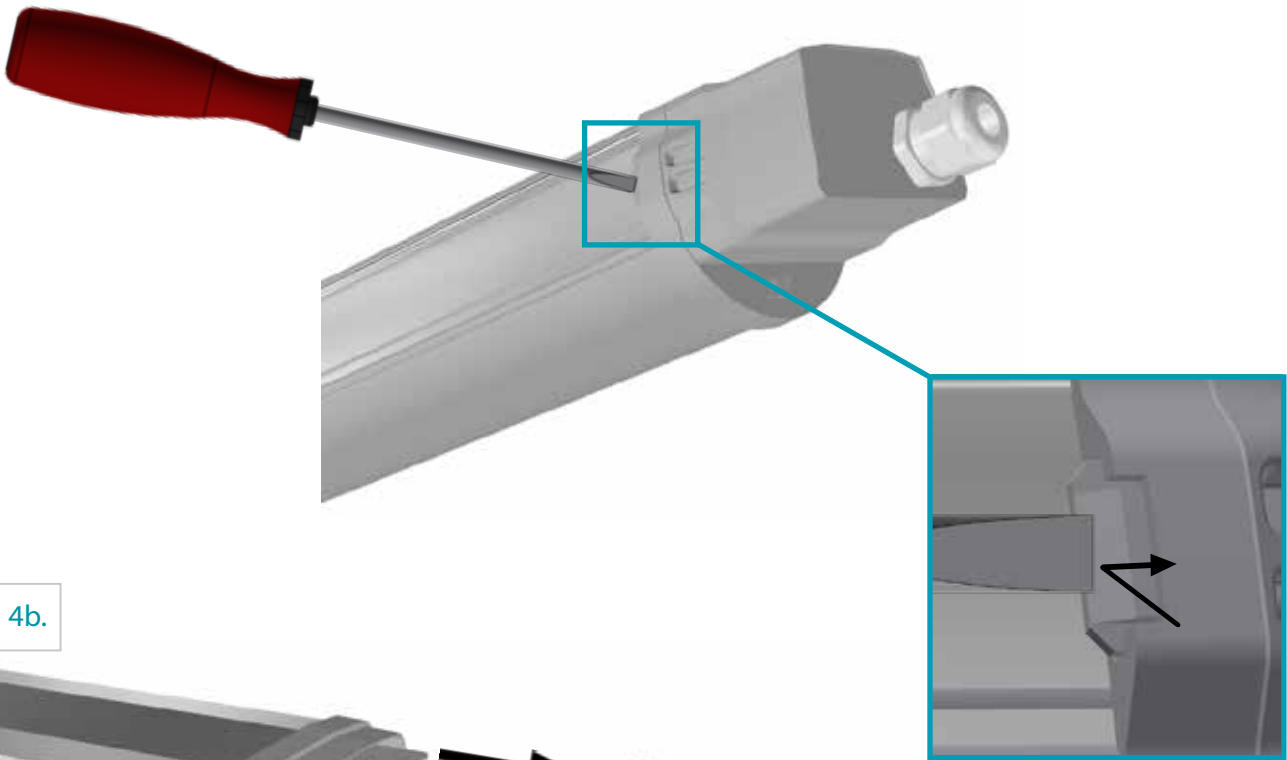

4b.

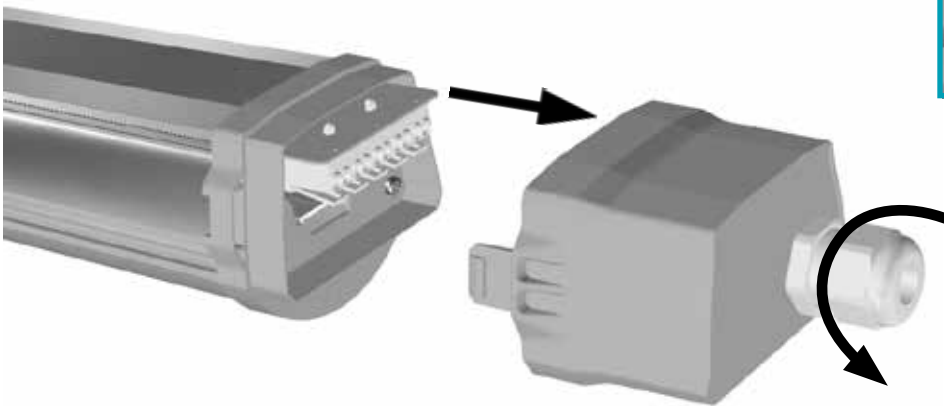

4c.

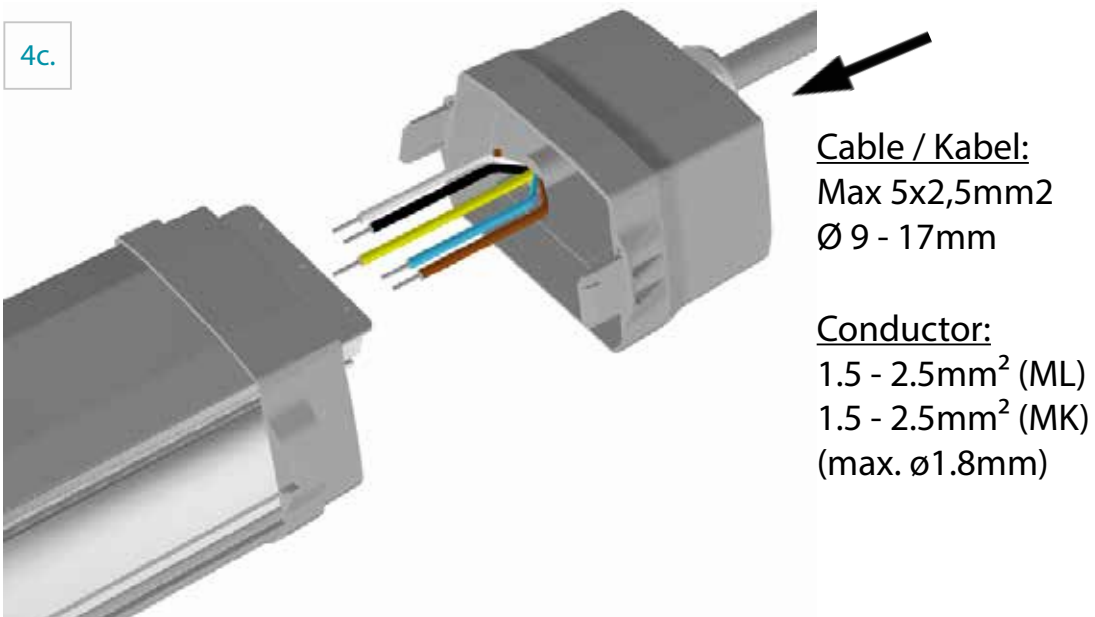

4d.

max. 60 mm
Cable stripping / Kabel abisolieren

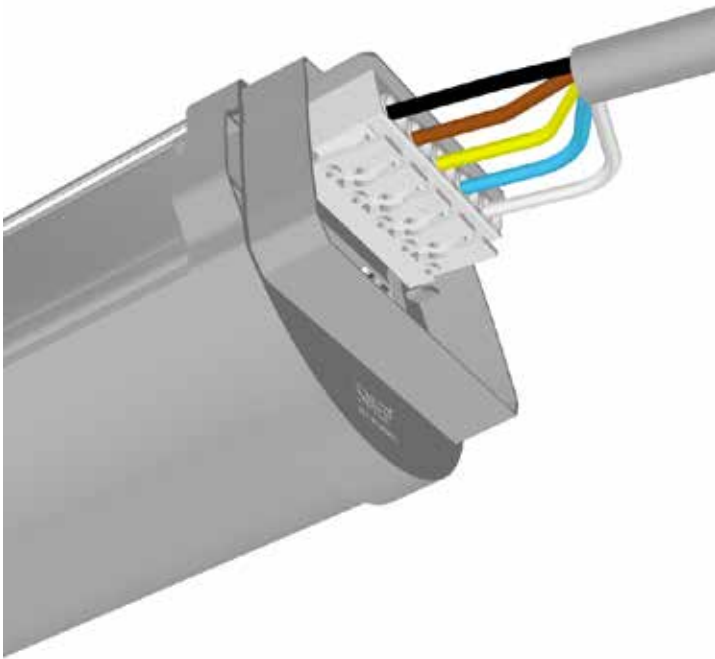

4e. Coupling | Anschluss



The connection must be made according to the room protection rating and, if necessary, using a distribution box that provides the required protection rating. When the luminaire is equipped with preassembled connection cable, one cannot open the luminaire nor change the cable.

Der Anschluss muss entsprechend der Schutzklasse und wenn benötigt mit Verteilerkasten isoliert werden um die benötigte IP- Schutzart zu erreichen. Wenn die Leuchte mit einem vormontierten Verbindungskabel ausgestattet ist, kann weder die Leuchte geöffnet noch das Kabel gewechselt werden.

Terminal block 3-phase
Klemmblock 3 phasing

DALI

Wire color
Drahtfarbe

| | | | |
|---|---|---|-------------------------|
| 2 | L2 | DA- / 2 | black/Schwarz |
| 1 | L1 | L | Brown / Braun |
|  |  |  | Yellow-green / Gelbgrün |
| N | N | N | Blue / Blau |
| 3 | L3 | DA+ / 1 | Gray / Grau |

NOTE!

Basic insulation must be maintained between the mains voltage components and the DALI control circuit. (IEC60598-1: 3.3.22)

ACHTUNG!

Basisisolierung muss gewährleistet zwischen Netzspannung und DALI-Steuerkreisleitung

connection and cable types
Anschluss- und Kabeltypen

| | | |
|----------------------|------------------------------|--|
| MSK / PVC / H05VV-F | White / Weib | Indoor use / Verwendung im Innenbereich |
| VSN / VSKB / H07RN-F | Black / Schwarz | Outdoor use / industrial Einsatz im Freien / industriell |
| MSK / HF / H05Z1Z1-F | Black / White Schwarz / Weib | Indoor use / industrial Verwendung im Innenbereich / industriell |
| VSN / HF / H07ZZ-F | Black / White Schwarz / Weib | indoor and outdoor use / industrial Innen- und Außeneinsatz / Industri |

4f. 7 pole connector.
7-poliger Stecker.

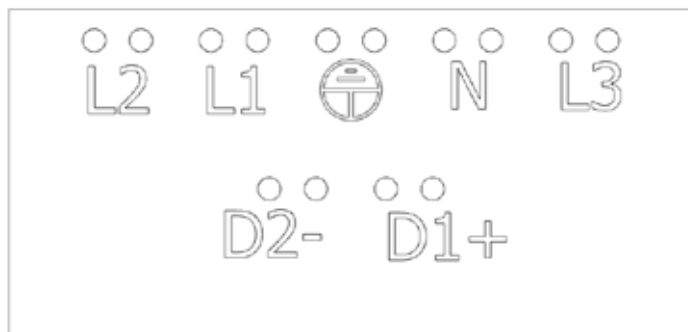
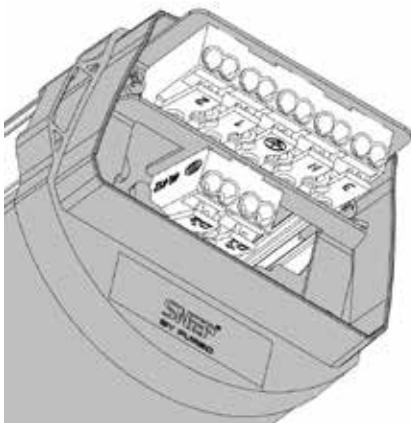
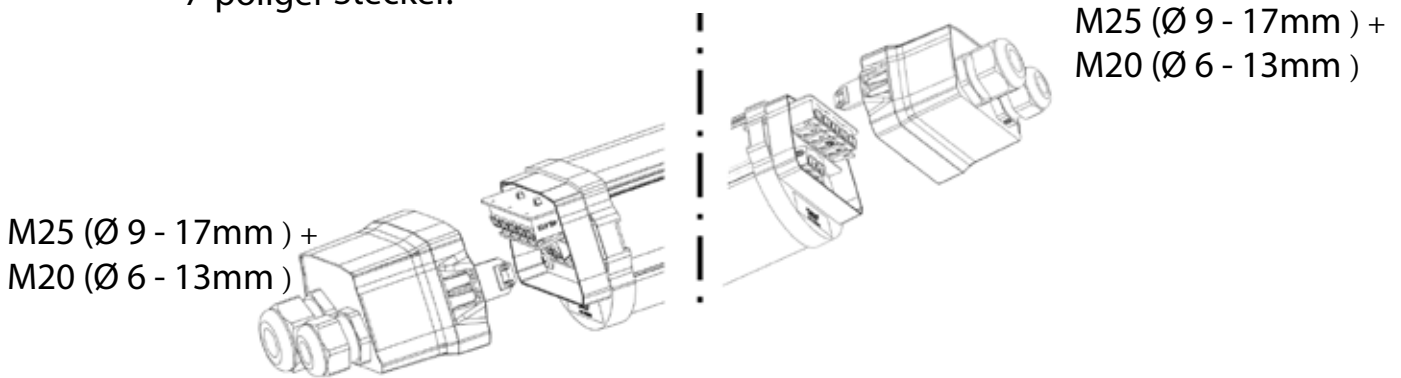

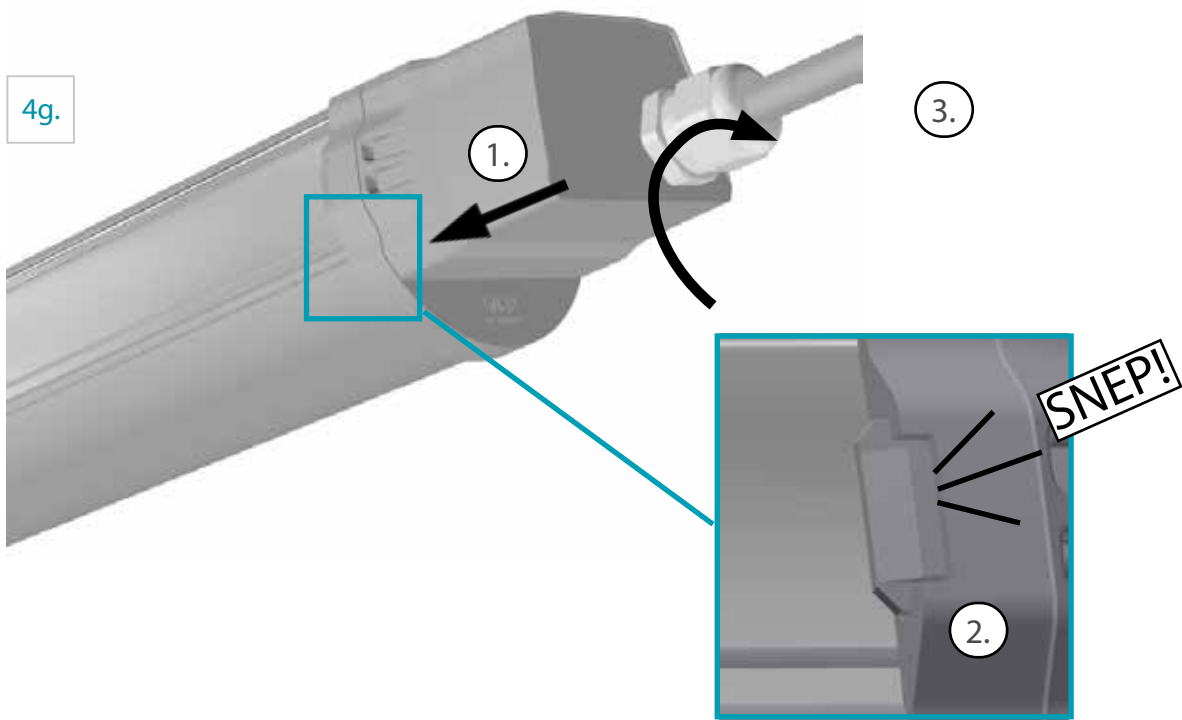

5. stepDIM motion sensor | stepDIM Bewegungssensor

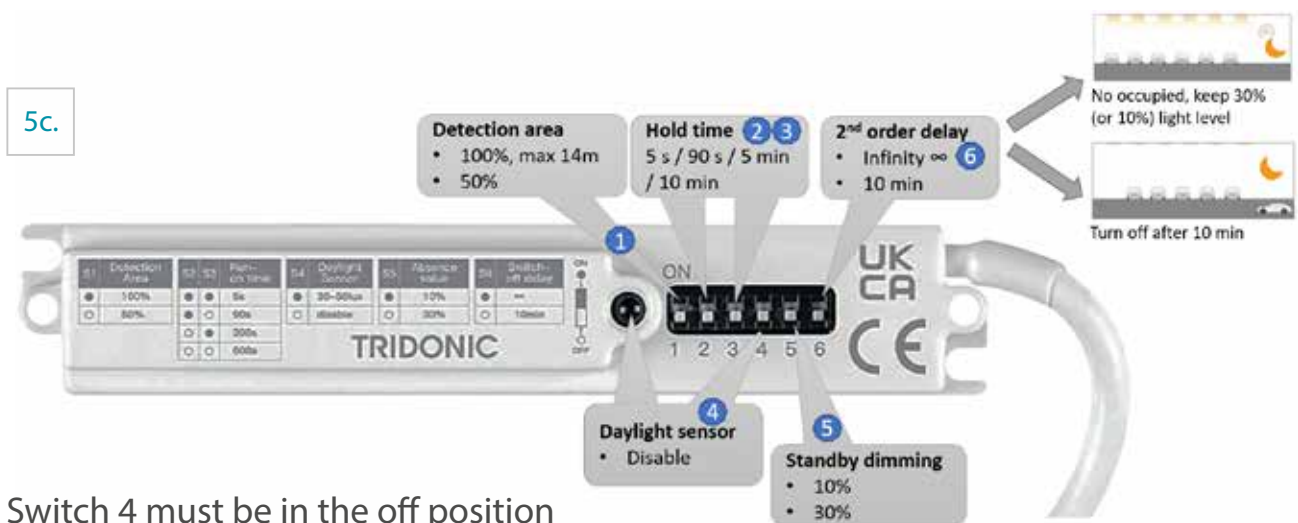
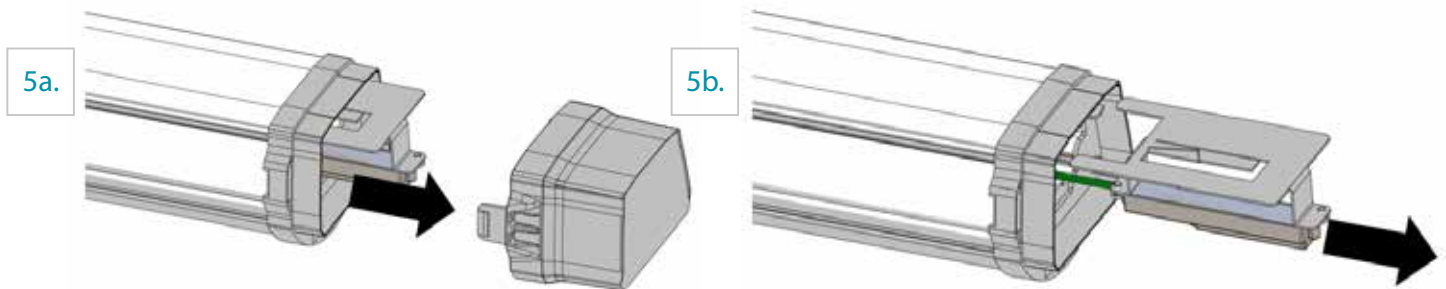

Switch 4 must be in the off position

Schalter 4 muss auf Aus stehen

5d.

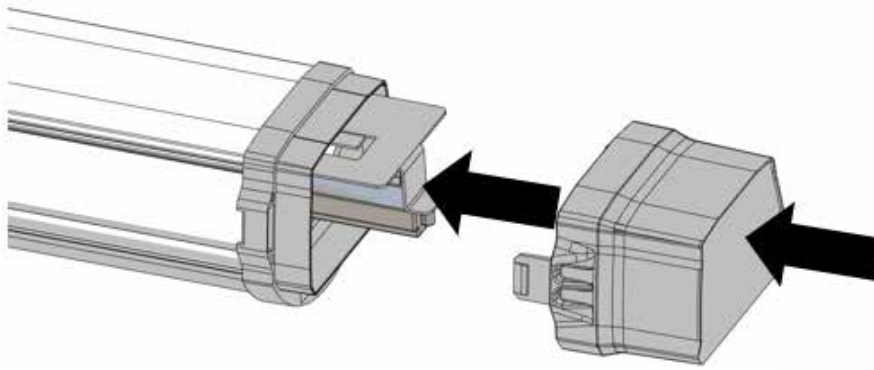

| Mounting height (h) Montagehöhe (h) | Detection diameter at 1 m/s moving speed (d) Erkennungsdurchmesser bei einer Bewegungsgeschwindigkeit von 1 m/s (d) | |
|--|--|---------------------------------|
| | 100 % Sensitiv / Empfindlichkeit | 50 % Sensitiv / Empfindlichkeit |
| 0.5 m | 4.5 m | 2.0 m |
| 1.0 m | 5.0 m | 2.5 m |
| 1.5 m | 5.0 m | 2.5 m |
| 2.0 m | 5.0 m | 2.5 m |
| 2.5 m | 5.5 m | 3.0 m |
| 3.0 m | 6.0 m | 3.0 m |
| 3.5 m | 5.5 m | 3.0 m |
| 4.0 m | 5.0 m | 2.0 m |
| 4.5 m | 5.0 m | 2.0 m |
| 5.0 m | 4.0 m | 2.0 m |
| 5.5 m | 3.0 m | 1.0 m |
| 6.0 m | 2.0 m | 1.0 m |

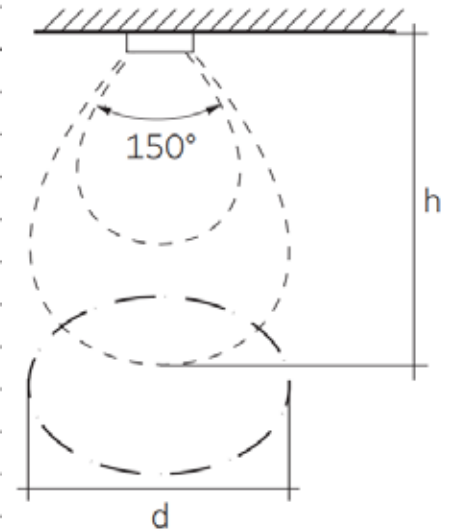

6. Active Ahead IP65 sensor / DALI IP65 sensor

Low Bay versio:

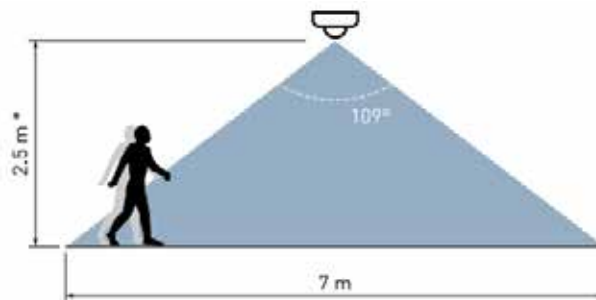
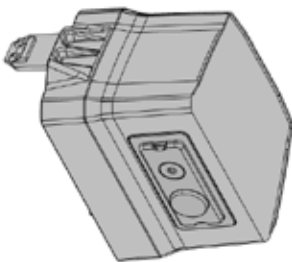

* Max recommended height 4 m

* Maximan empfohlene Höhe 4 m

High Bay versio:

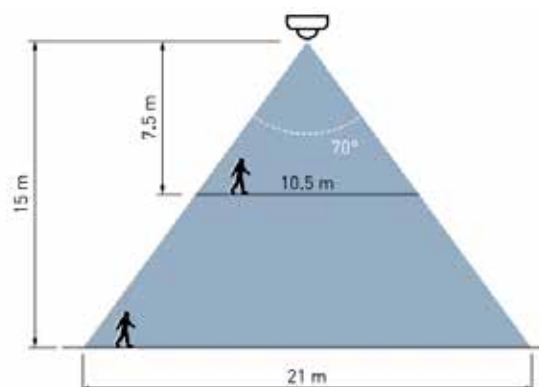
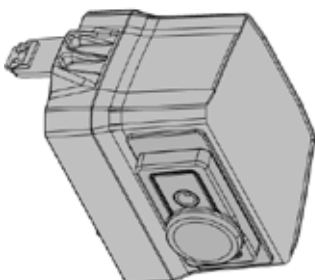

7. Philips MasterConnect

Low Bay versio:

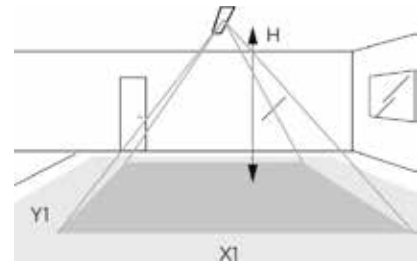
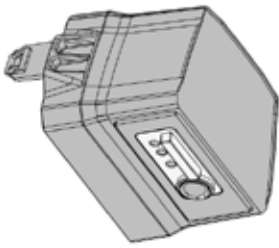

| Height (H) | Minor movement | | Major movement | |
|------------|----------------|-----|----------------|-----|
| | X1 | Y1 | X2 | Y2 |
| 2.4m | 1.9 | 2.9 | 2.9 | 4.3 |
| 3.0m | 2.4 | 3.6 | 3.6 | 5.4 |

8. Luminaire maintenance | Leuchtenwartung

8a.

Serial number
Seriennummer



+358 (0)3 3404 111
snep@purso.fi
purso.fi

8b.

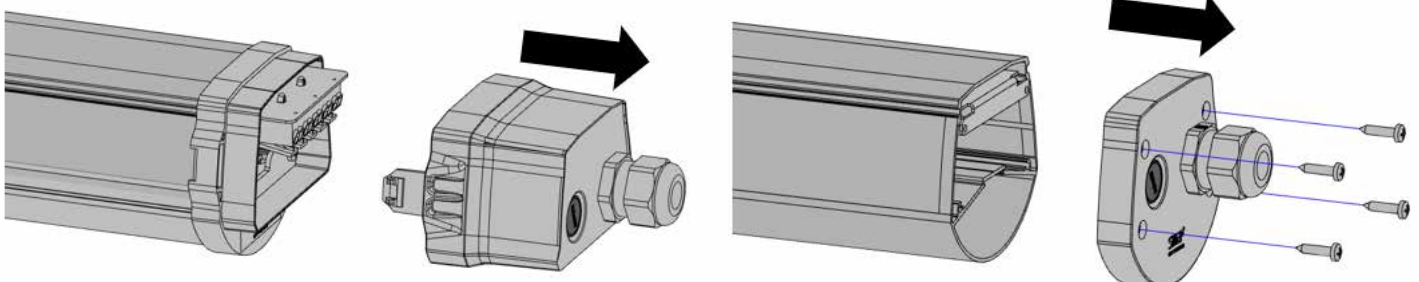

8c.

Replacement of light source Austausch der Lichtquelle

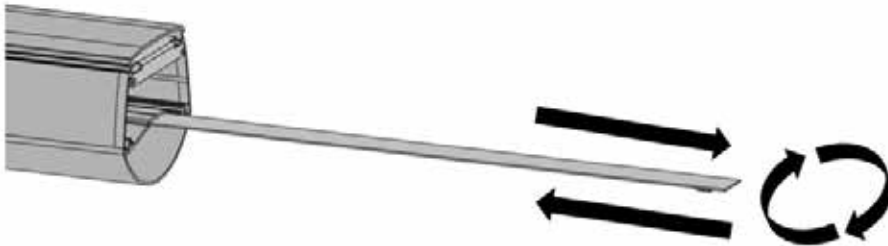
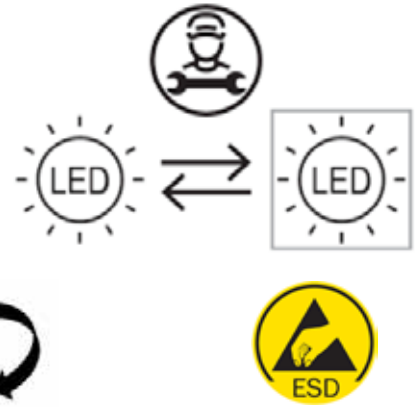
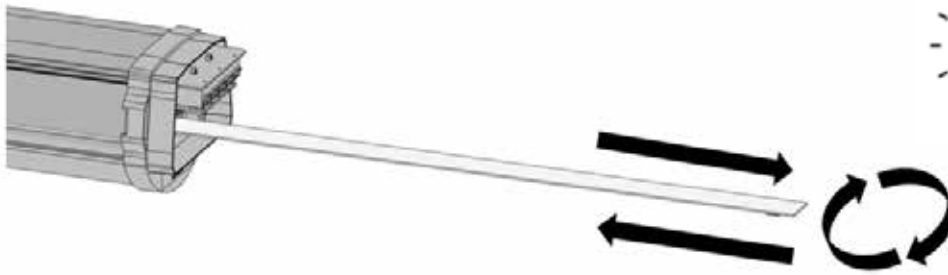

8d.

Replacement of control gear Austausch von Betriebsgeräten

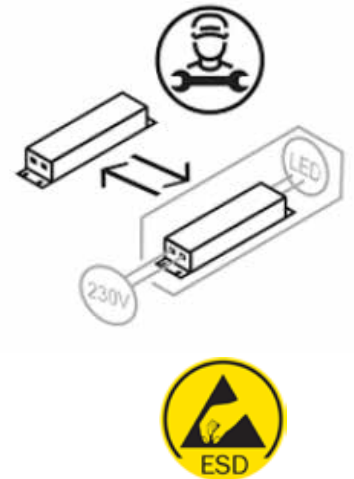
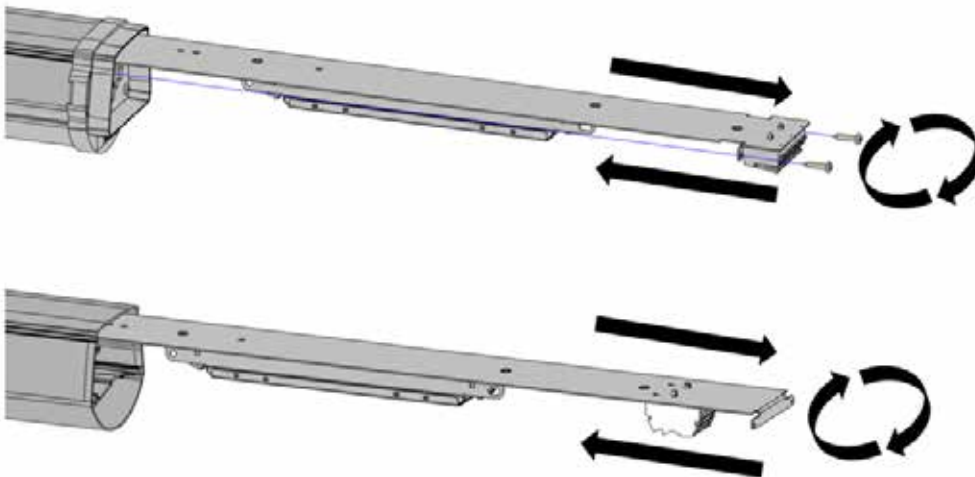

8e.

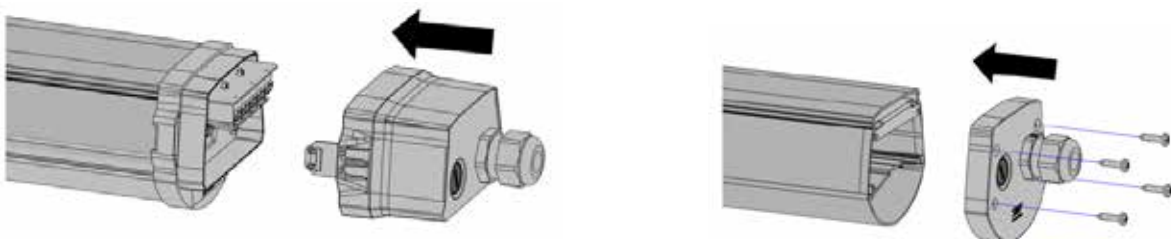

SNEP[®]

BY PURSO



Luminaire and packing materials have to be disposed of according to local requirements.

Entsorgen Sie die Leuchten und Verpackungsmaterialien gemäß den örtlich geltenden Entsorgungsbestimmungen.

Specifications subject to change without notice.

Alle Rechte für Änderung sind vorbehalten.

Purso Oy
Alumiinitie 1
FI-37200 Siuro

+358 (0)3 3404 111
snep@purso.fi
purso.fi

 **PURSO[®]**